

# TEKNIKRESURS

## WOOD PROCESSING TECHNOLOGY

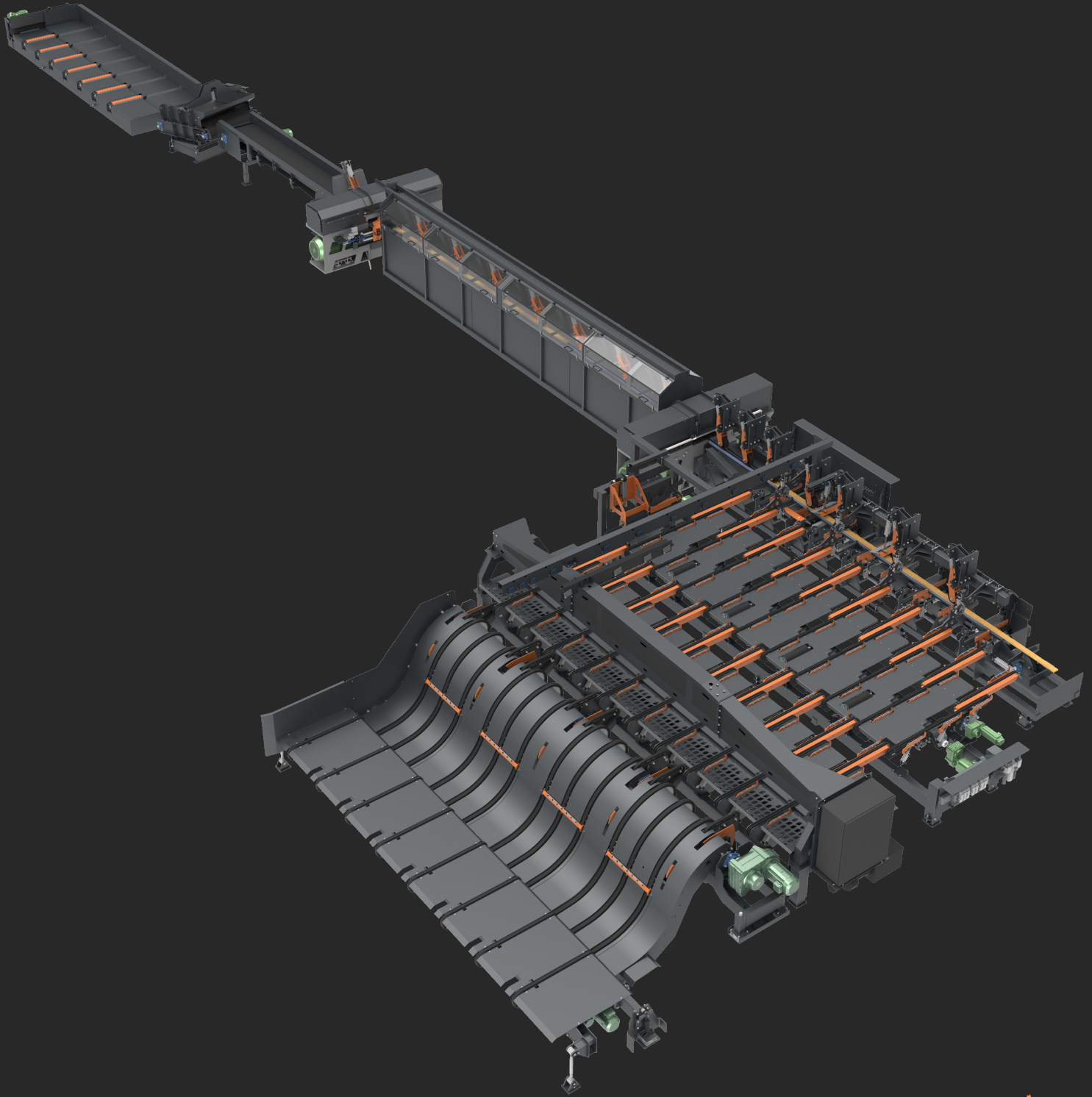

Svensk kvalité • Swedish Quality • Schwedische Qualität



# TEKNIKRESURS

WOOD PROCESSING TECHNOLOGY



# TEKNIKRESURS

## WOOD PROCESSING TECHNOLOGY

SE

Höga Kusten Teknikresurs erbjuder marknadens bredaste kantningsprogram. Med stort kunnande och gedigen erfarenhet anpassas våra system efter var kunds behov. Kantningssystem med kapacitet upp till +60 bitar/min.

EN

Höga Kusten Teknikresurs offers the market's biggest range of edging programs. With extensive knowledge and experience, our systems are adapted to each customer's needs. Edging system with capacity up to +60 boards/min.

DE

Höga Kusten Teknikresurs bietet das größte Besäum Programm am Markt an. Die Systeme werden mit genuiner Erfahrung und Kenntnis an die Kundenforderungen angepasst. Besäum Systeme mit Leistungen bis zu +60 Bretter pro Minute.

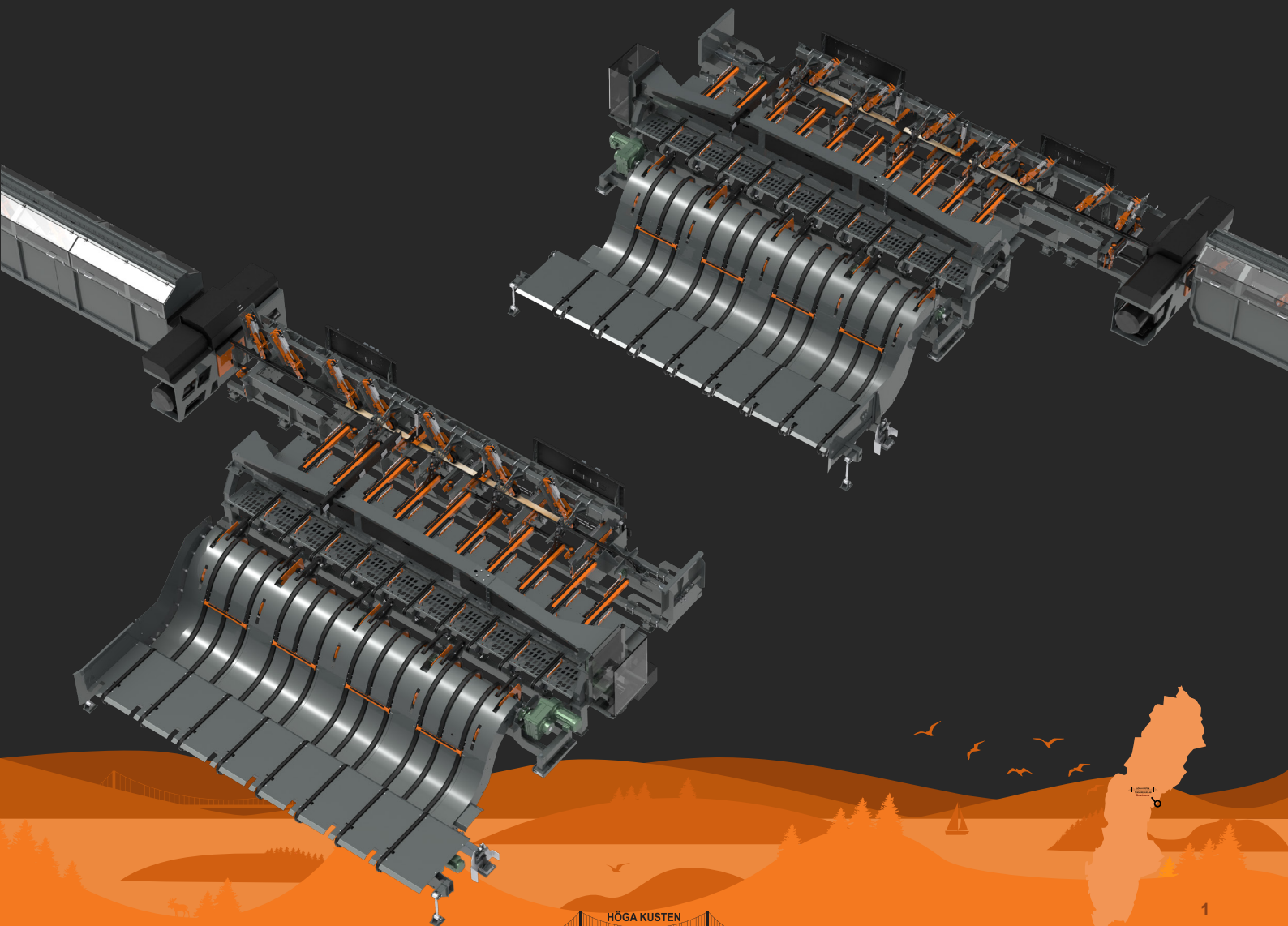

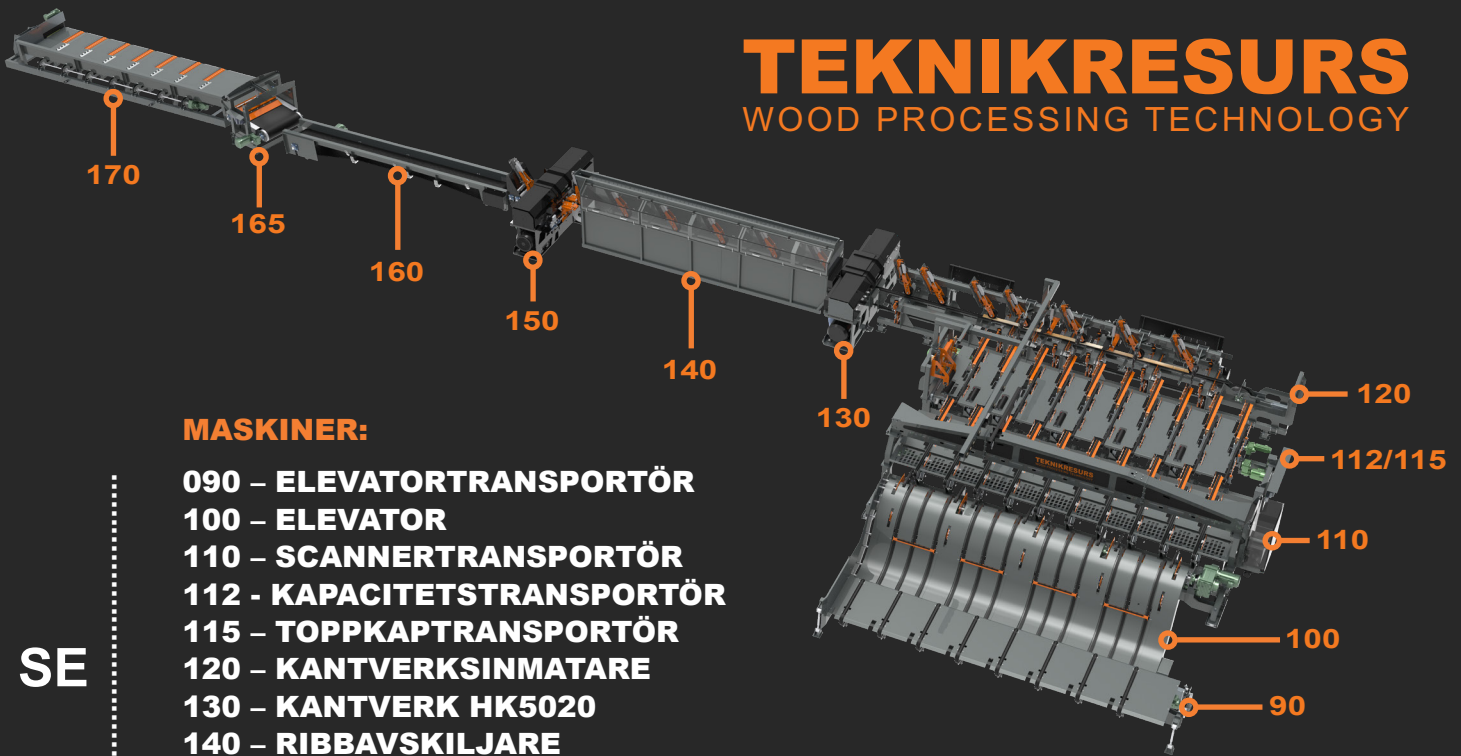

SE

## MASKINER:

- 090 – ELEVATORTRANSPORTÖR
- 100 – ELEVATOR
- 110 – SCANNERTRANSPORTÖR
- 112 – KAPACITETSTRANSPORTÖR
- 115 – TOPPKAPTRANSPORTÖR
- 120 – KANTVERKSINMATARE
- 130 – KANTVERK HK5020
- 140 – RIBBAVSKILJARE
- 150 – KANTVERK HK5010
- 160 – BANDTRANSPORTÖR
- 165 – SLOW DOWN BELT
- 170 – AVLÄGG

EN

## MACHINES:

- 090 – UNSCRAMBLER CONVEYOR
- 100 – UNSCRAMBLER
- 110 – SCANNING CONVEYOR
- 112 – CAPACITY CONVEYOR
- 115 – TOP SAW CONVEYOR
- 120 – EDGER INFEEED
- 130 – EDGER HK5020
- 140 – EDGER OUTFEED
- 150 – EDGER HK5010
- 160 – BELT CONVEYOR
- 165 – SLOW DOWN BELT
- 170 – UNLOADING CONVEYOR

DE

## MASCHINEN:

- 090 – VOR-ENTZERR-QUERFÖRDERER
- 100 – VEREINZELER
- 110 – MESS-QUERFÖRDERER
- 112 – KAPAZITÄTSFÖRDERER
- 115 – KAPPFÖRDERER
- 120 – EINZUGSTISCH
- 130 – BESÄUMER HK5020
- 140 – SPREIßELABSCHIEDER
- 150 – AUFTRENNMASCHINE HK5010
- 160 – GURTFÖRDERER
- 165 – SLOW DOWN BELT
- 170 – ENTLADUNGSFÖRDERER



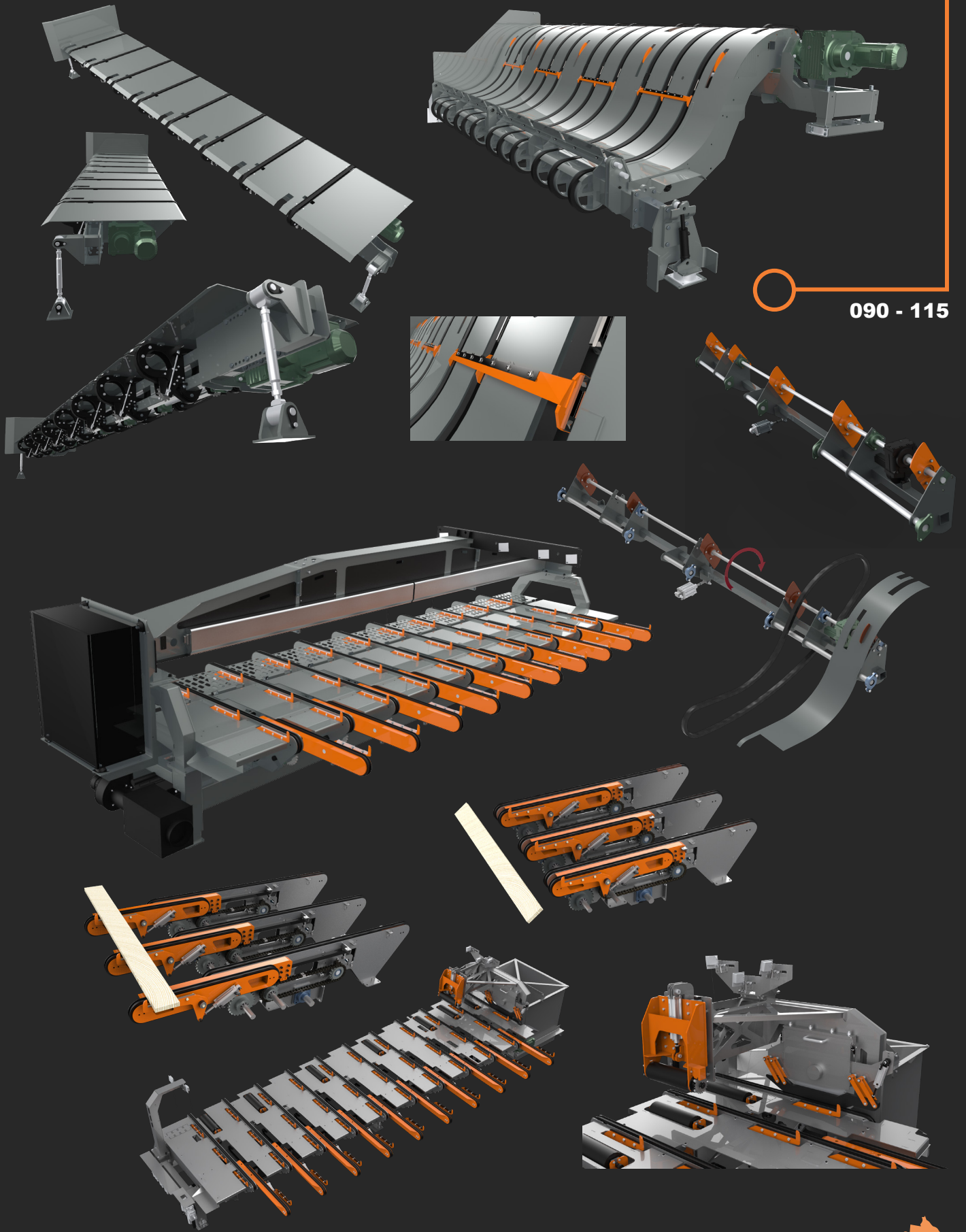

090 - 115



120 - 170

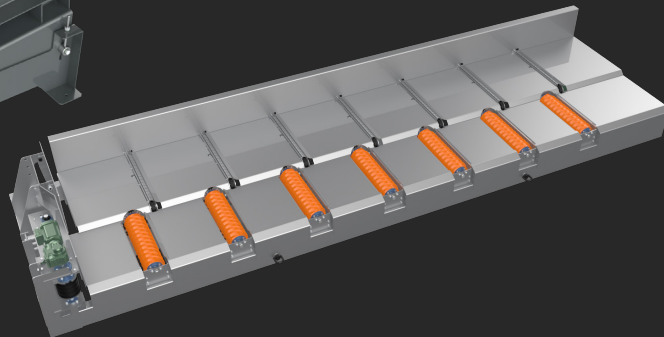
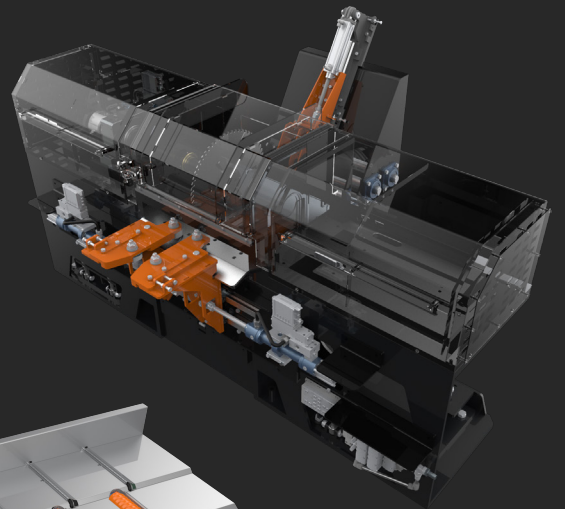
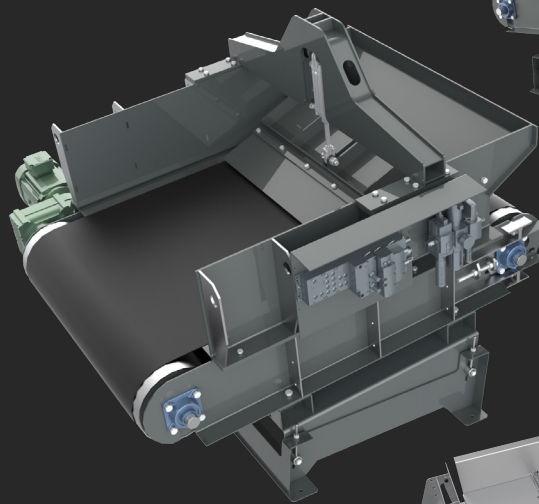
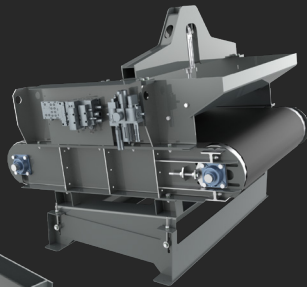
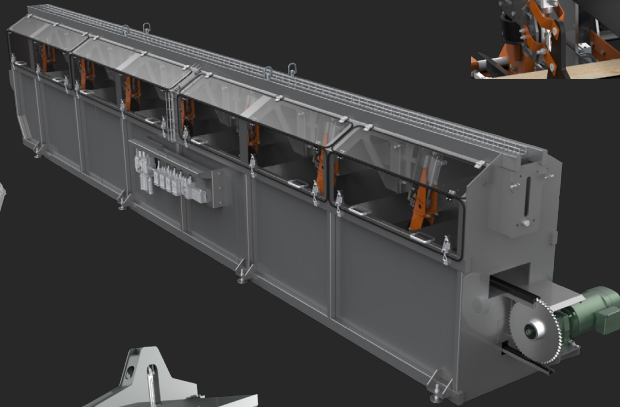
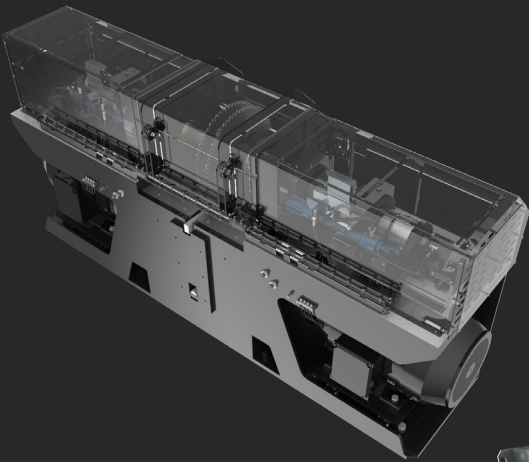
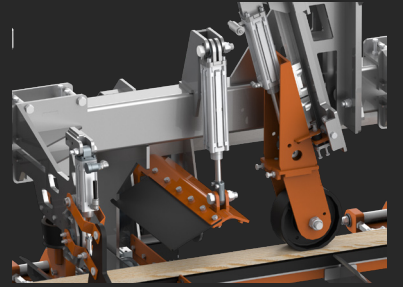
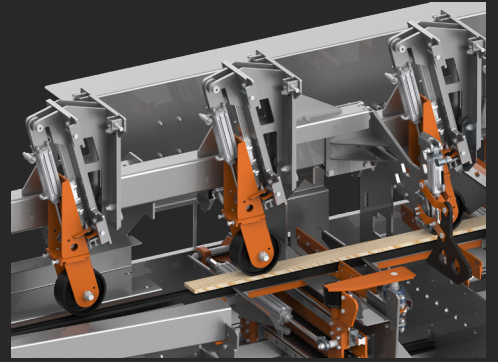
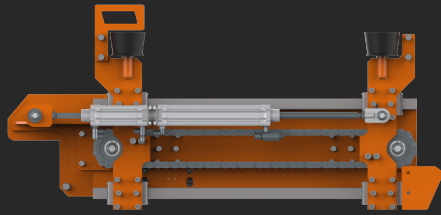

# Bräddata • Board data • Brett daten

Min tjocklek (mm) .....	16
Max tjocklek (mm) .....	75
Min längd (mm).....	2400
Max längd (mm).....	6100
Min okantad bredd (mm) .....	90
Max okantad bredd (mm) .....	500
Max okantad bredd m lägre kapacitet(mm).....	600
Min kantad bredd (mm) .....	60
Max kantad bredd (mm) .....	460 (560 med XL-kantverk)
Kapacitet: maximalt antal brädor/min vid 450 m/min.....	60
Genomsnittligt antal brädor vid 450 m/min .....	60

SE

Min thickness (mm) .....	16
Max thickness (mm) .....	75
Min length (mm).....	2400
Max length(mm).....	6100
Min non edged width (mm).....	90
Max non edged width (mm).....	500
Max non edged width w. lower capacity(mm).....	600
Min edged width (mm).....	60
Max edged width (mm).....	460 (560 for XL-edger)
Capacity: maximum boards/min at 450 m/min .....	60
Average boards/min at 450 m/min.....	60

EN

Min Stärke (mm).....	16
Max Stärke (mm).....	75
Min Länge (mm) .....	2400
Max Länge (mm) .....	6100
Min unbesäumte Breite (mm) .....	90
Max unbesäumte Breite (mm) .....	500
Max unbesäumte Breite mit weniger Leistung (mm) .....	600
Min besäumte Breite (mm) .....	60
Max besäumte Breite (mm) .....	460 (560 auf XL-Besäumer)
Durchschnittleistung brett pro minuten 450 m/min: .....	60
Maximal brett pro minuten at 450 m/min: .....	60

DE





# TEKNIKRESURS

## WOOD PROCESSING TECHNOLOGY

In 1993 Stefan Andersson founded Höga Kusten Teknikresurs. At this time he was the sole working engineer in the company. Today Höga Kusten Teknikresurs is a part of Arat Group, Andreas Fällidin is CEO and Stefan Andersson is CMO/CTO. Together with 30 employees, the company continues to grow with its headquarters in Svartnora, Sweden.

Our manufacturing takes place in our workshops in Svartnora and Nyland, as well as in close collaboration with a number of contract manufacturing workshops. This results in short lead times and high quality in both large and small projects.

### Our vision

Our vision is by responsiveness, creativity and flexibility establish a close and simple relationship to our customers. We want our customers to feel safe knowing that our service and product quality correspond to what we promise.

### Our business concept

Our business concept is to offer our customers high quality technical solutions, support through the whole process and product development specially designed to fulfill our customer's needs.

### Our services:



Mechanical engineering & product development

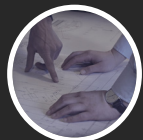

Project planning & management



Manufacturing, test & validation

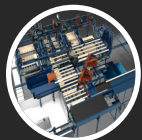

Product sales



Design & visualization



Education

### Our specialist skills:

- Mechatronic
- FMEA
- FEM
- CAD, PDM
- Risk analysis & CE marking according to current standards
- Mechanical engineering
- Hydraulic
- Pneumatic
- Sawmill technology & wood processing
- System solution engineering
- Laser cutting
- Vehicle & marine mec. Engineering



# TEKNIKRESURS

WOOD PROCESSING TECHNOLOGY

**+46613-510 48**

**[www.teknikresurs.se](http://www.teknikresurs.se)**

[info@teknikresurs.se](mailto:info@teknikresurs.se)